

## Piantana in piatto ad annegare

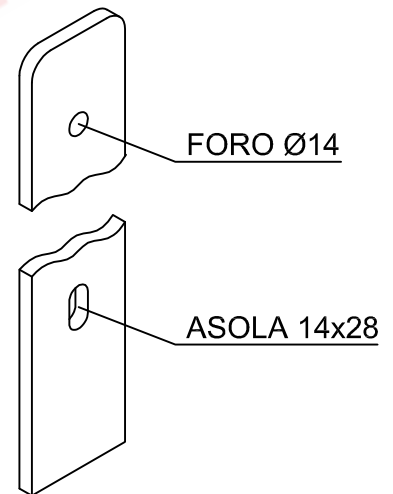
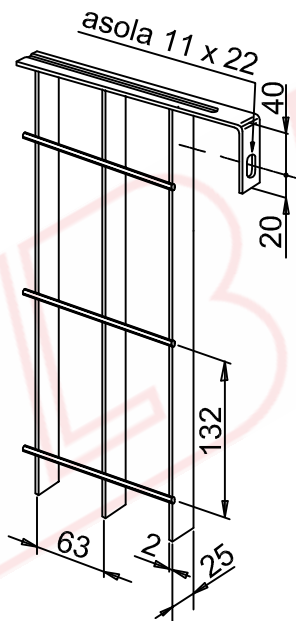
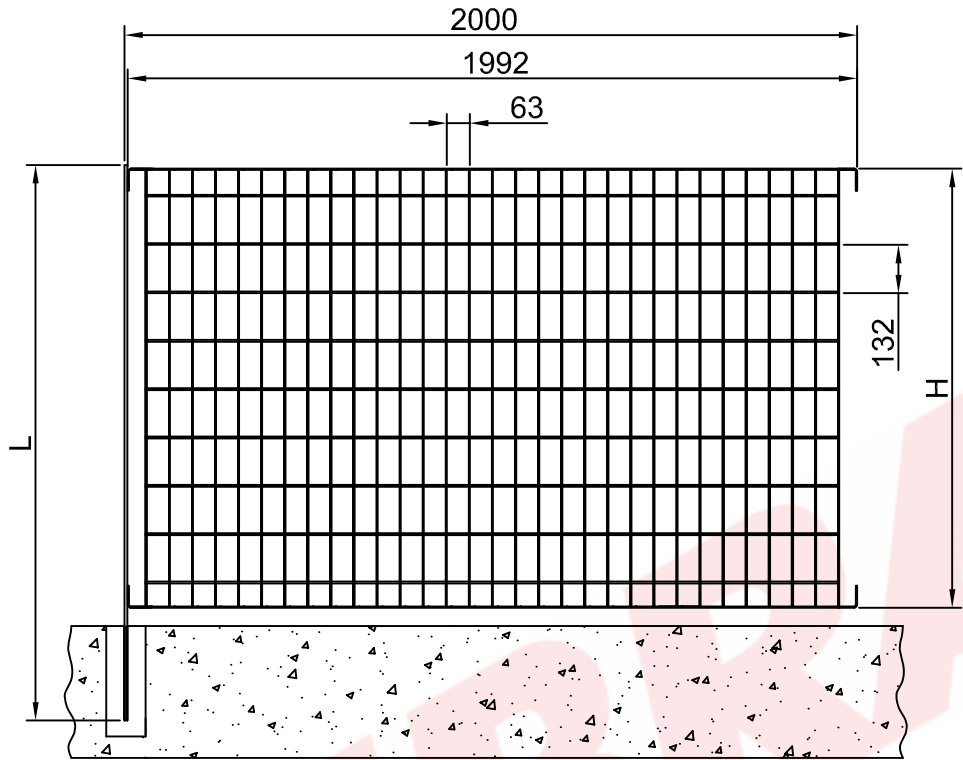

Altezza pannello mm	Peso pannello kg/cad	Tipo piantana mm	Altezza piantana mm	Peso piantana kg/cad
930	15,1	≠ 60x7	1200	4,2
1195	18,6	≠ 60x7	1465	5,1
1320	20,3	≠ 60x7	1650	5,8
1460	22,1	≠ 60x7	1790	6,3
1720	25,6	≠ 60x7	2085	7,3
1985	29,1	≠ 60x7	2350	8,2

Materiale: S235JR EN 10025

Trattamento superficiale: Zincatura a caldo UNI EN ISO 1461

## Piantana in piatto con piastra di base

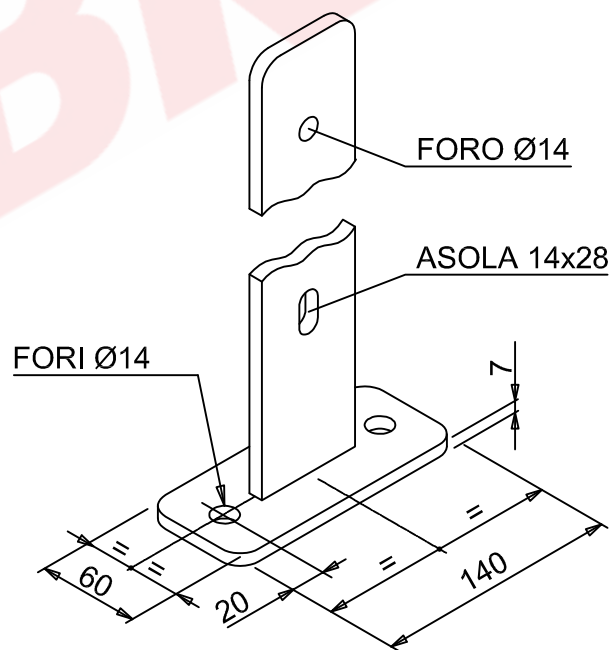
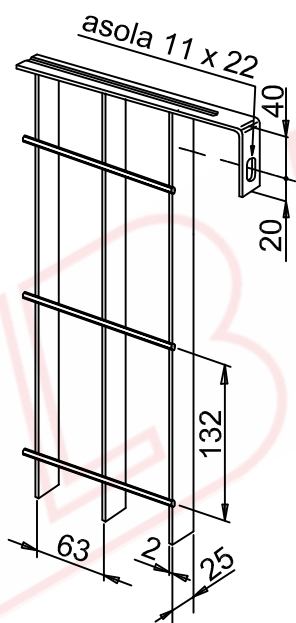
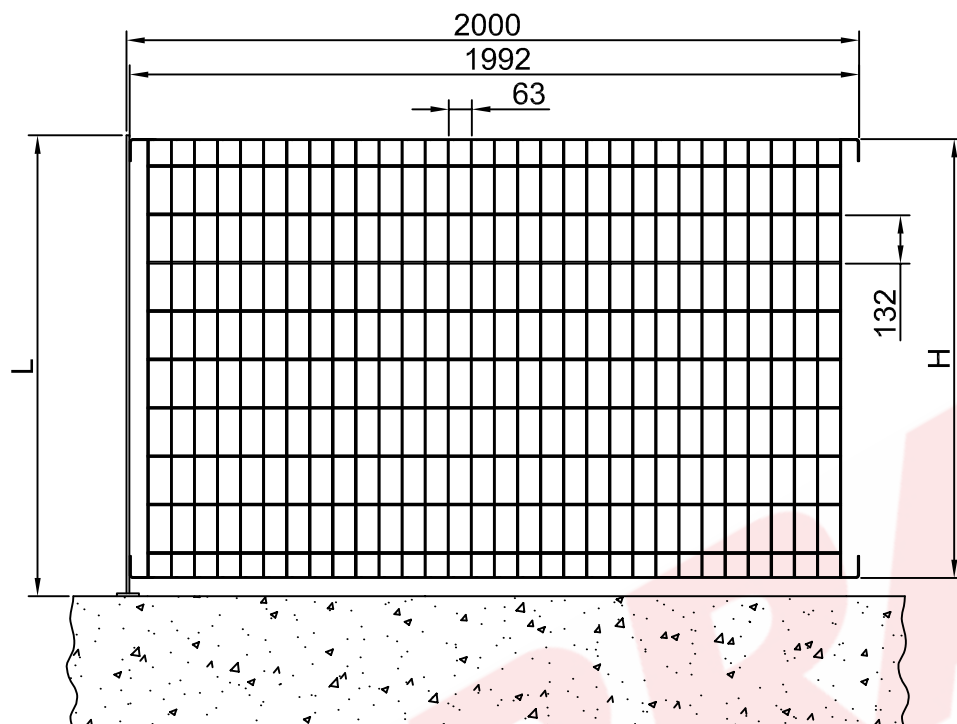

Altezza pannello mm	Peso pannello kg/cad	Tipo piantana mm	Altezza piantana mm	Peso piantana kg/cad
930	15,1	≠ 60x7	990	3,9
1195	18,6	≠ 60x7	1255	4,9
1320	20,3	≠ 60x7	1380	5,3
1460	22,1	≠ 60x7	1520	5,8
1720	25,6	≠ 60x7	1780	6,7
1985	29,1	≠ 60x7	2045	7,6

Materiale: S235JR EN 10025

Trattamento superficiale: Zincatura a caldo UNI EN ISO 1461

# Aurora 2

**LIBRA**

## Piantana STYLE ad annegare

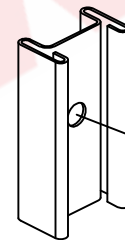
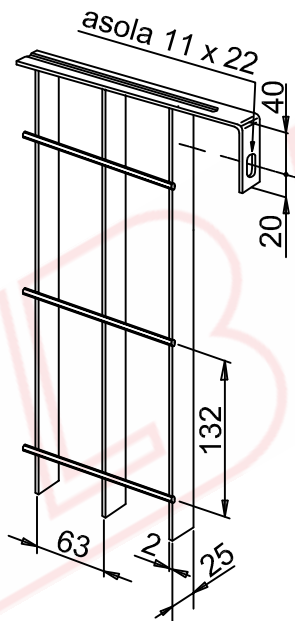
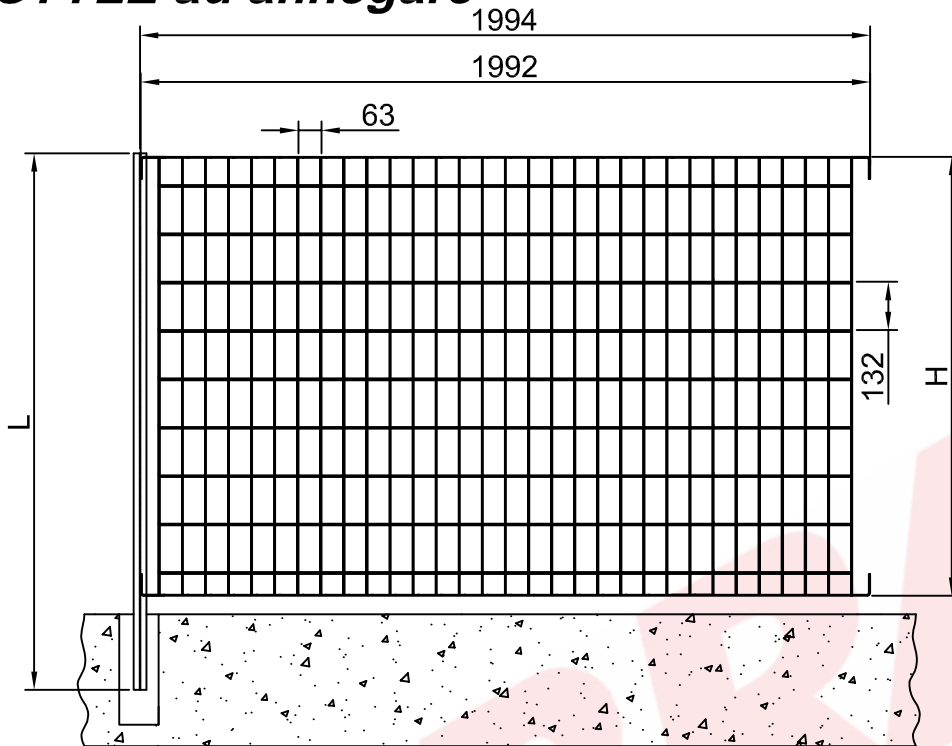

FORO Ø14

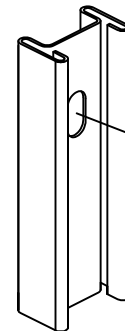

ASOLA 14x28

Altezza pannello mm	Peso pannello kg/cad	Tipo piantana	Altezza piantana mm	Peso piantana kg/cad
930	15,1	PROFILATA	1200	3,0
1195	18,6	PROFILATA	1465	3,7
1320	20,3	PROFILATA	1650	4,2
1460	22,1	PROFILATA	1790	4,5
1720	25,6	PROFILATA	2085	5,3
1985	29,1	PROFILATA	2350	6,0

Materiale: S235JR EN 10025

Trattamento superficiale: Zincatura a caldo UNI EN ISO 1461

## Piantana STYLE con piastra di base

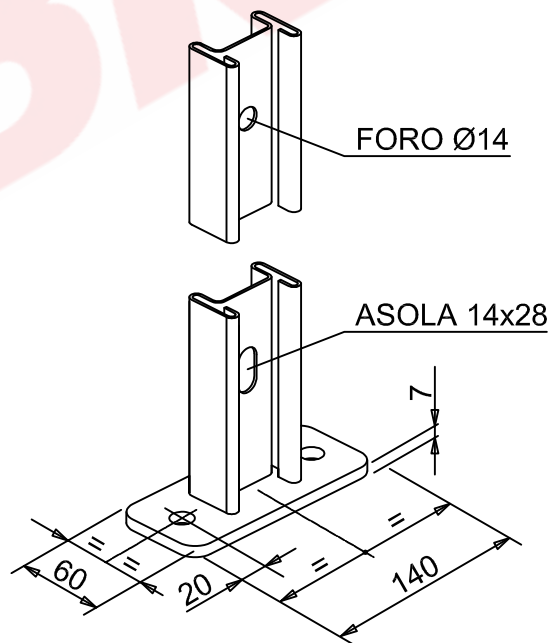
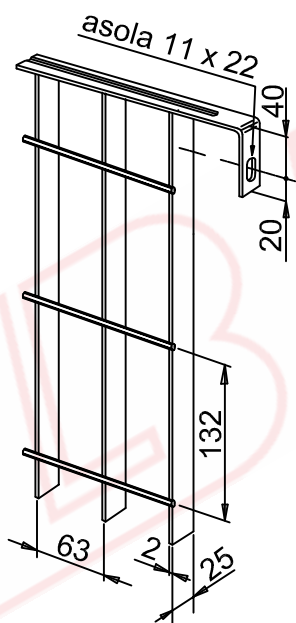
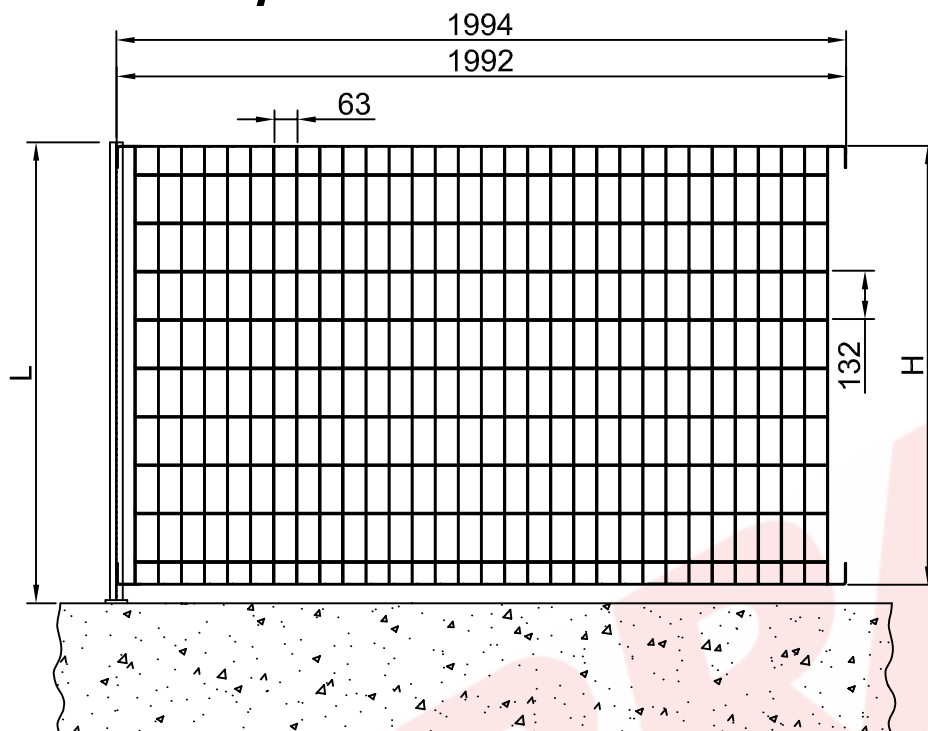

Altezza pannello mm	Peso pannello kg/cad	Tipo piantana	Altezza piantana mm	Peso piantana kg/cad
930	15,1	PROFILATA	990	3,0
1195	18,6	PROFILATA	1255	3,7
1320	20,3	PROFILATA	1380	4,0
1460	22,1	PROFILATA	1520	4,3
1720	25,6	PROFILATA	1780	5,0
1985	29,1	PROFILATA	2045	5,7

Materiale: S235JR EN 10025

Trattamento superficiale: Zincatura a caldo UNI EN ISO 1461